

## SCM-ST Series STAINLESS STEEL CENTRIFUGAL PUMP

SCM-ST series STAINLESS STEEL centrifugal pumps are single stage, high efficient electric pumps, consisted of a miniature motor and a single impeller centrifugal pump.

The pump and the impeller are made of stainless steel, make it better and ideal for pumping drinking water.

They have a good performance in Big Capacity and High Head.



SCM-34ST

### CONSTRUCTION:

#### PUMP Peripheral

Pump Body: Stainless Steel

Impeller: Stainless Steel

Mechanical Seal: Carbon / Ceramic / Stainless steel

#### MOTOR Single Phase Heavy Duty Continuous Work

Motor Housing: Aluminum

Shaft: Stainless Steel

Insulation: Class B / Class F

Protection: IP44 / IP54

Cooling: External ventilation

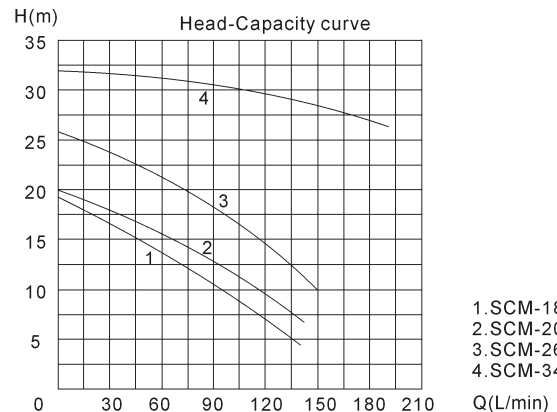
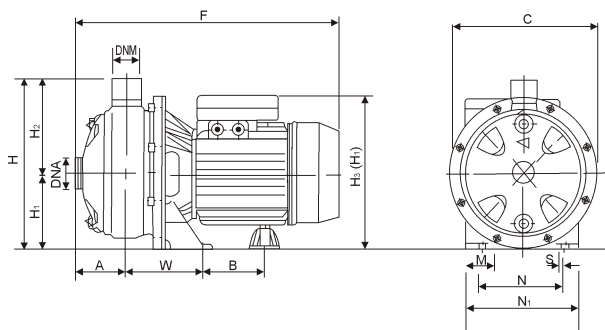

### PERFORMANCE SPECIFICATIONS

Model	Power		Q.max. L/min	H.max. m	Suct.max. m	Speed r.p.m	Inlet/Outlet mm	PACKAGE DIMENSIONS & G.W.			
	HP	kW						A	B	H	kg
SCM-18ST	0.5	0.37	140	18	9	2850	30x25	390	220	270	12.0
SCM-20ST	0.75	0.55	145	20			30x25	390	220	270	12.5
SCM-26ST	1	0.75	150	26			30x25	390	220	270	13.5
SCM-34ST	1.5	1.1	192	34			30x25	400	260	330	24.0

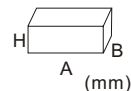

\* 110V, 110V/220V, 60Hz etc. models are available on request.

### OVERALL & INSTALLATION DIMENSIONS

Model	DIMENSIONS (mm)															
	DNA	DNM	A	C	F	H	H1	H2	H3	H4	M	N	N1	S	W	B
SCM-18ST	G1.25"	G1"	52	213	315	232	108	124	241	213	39	120	158	9	92	82
SCM-20ST	G1.25"	G1"	52	213	315	232	108	124	241	213	39	120	158	9	92	82
SCM-26ST	G1.25"	G1"	52	213	315	232	108	124	241	213	39	120	158	9	92	82
SCM-34ST	G1.25"	G1"	52	240	365	257	120	137	241	213	39	140	180	9	92	82