

LHF2 Series CENTRIFUGAL PUMP



LHF2 series centrifugal pumps are singlestage, high efficient electric pumps, consisted of a miniature motor and a single impeller centrifugal pump. They have a good performance in Big Capacity.

They are widely used in well-pumping, water supplying, decanting, mixing and irrigating for civil, industry and agriculture, etc.

PERFORMANCE SPECIFICATIONS

Model		Power		Q	H																			
Monofase	Trifase	HP	kW		m ³ /h	0	6	12	18	24	30	36	42	48	54	60	66	72	78	84	90	96	102	108
				L/min	0	100	200	300	400	500	600	700	800	900	1000	1100	1200	1200	1400	1500	1600	1700	1800	
LHF2-4	LH4	1	0.75		10	9.8	9.3	8.7	8	7	6	4.7	3											
LHF2-6C	LF6C	1.5	1.1		11.9	--	11.7	11.3	10.7	10.2	9.2	8	6.7	5	3									
LHF2-6B	LH6B	2	1.5		14.7	--	14.5	14	13.5	12.8	12	11	9.7	8.2	6.7	5								
-----	LH6A	3	2.2		18.5	--	18.1	17.8	17.2	16.8	16	15	13.8	12.2	10.5	8.3	6							
LHF2-6CR	LH6CR	1.5	1.1		11.9	--	11.7	11.3	10.7	10.2	9.2	8	6.7	5	3									
LHF2-6BR	LH6BR	2	1.5		14.7	--	14.5	14	13.5	12.8	12	11	9.7	8.2	6.7	5								
-----	LH6AR	3	2.2		18.5	--	18.1	17.8	17.2	16.8	16	15	13.8	12.2	10.5	8.3	6							
-----	LH8B	4	3		21.5	--	21	20.7	20	19.5	18.8	17.8	16.5	15	13.5	11.2	9							
-----	LH8A	5.5	4		24.5	--	24	23.5	23	22.5	21.8	20.8	19.5	18.3	16.8	15	13							
-----	LH20B	4	3		16	--	--	--	15.5	15.4	15.3	15.2	15	14.5	14	13	12	10.7	9	7	4.8	2		
-----	LH20A	5.5	4		19	--	--	--	18.5	18.4	18.3	18.2	18	17.5	17	16.2	15.2	13.7	12	10	7.8	5	2	

* 110V, 110V/220V, 60Hz etc. models are available on request.

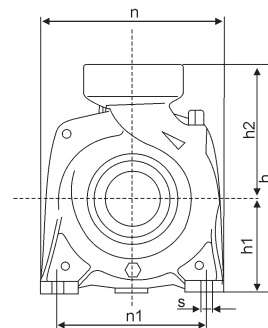
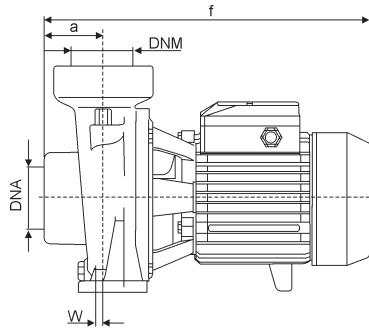

OVERALL & INSTALLATION DIMENSIONS

Model		DNA	DNM	DIMENSIONS(mm)								
Monofase	Trifase			a	f	h	h1	h2	n	n1	w	s
LHF-4	LH-4	2"	2"	55	323	240	97	143	190	155	-	10
LHF-6C	LH-6C	3"	3"	68	385	312	120	192	240	190	6	12
LHF-6B	--	3"	3"	68	405	312	120	192	240	190	6	12
--	LH-6B	3"	3"	68	385	312	120	192	240	190	6	12
--	LH--6A	3"	3"	68	405	312	120	192	240	190	6	12
LHF-6CR	LH--6CR	4"	4"	70	387	312	120	192	240	190	6	12
LHF--6BR	--	4"	4"	70	407	312	120	192	240	190	6	12
--	LH--6BR	4"	4"	70	387	312	120	192	240	190	6	12
--	LH--6AR	4"	4"	70	407	312	120	192	240	190	6	12
--	LH-8B	4"	4"	80	429	312	132	180	245	190	30	14
--	LH-8A	4"	4"	80	475	312	132	180	245	190	30	14
--	LH-20B	4"	4"	80	429	312	132	180	245	190	30	14
--	LH-20A	4"	4"	80	475	312	132	180	245	190	30	14