

# DTM Series

## CENTRIFUGAL PUMP

DTM series centrifugal pumps are singlestage, high efficient electric pumps, consisted of a miniature motor and a single impeller centrifugal pump. They have a good performance in Big Capacity and High Head. They are widely used in well-pumping, water supplying, decanting, mixing and irrigating for civil, industry and agriculture, etc.



DTM-20A

### CONSTRUCTION:

#### PUMP Peripheral

Pump Body: Cast Iron  
Impeller: Brass  
Mechanical Seal: Carbon / Ceramic / Stainless steel

#### MOTOR Single Phase Heavy Duty Continuous Work

Motor Housing: Aluminium  
Shaft: Carbon Steel / Stainless Steel  
Insulation: Class B / Class F  
Protection: IP44 / IP54  
Cooling: External ventilation

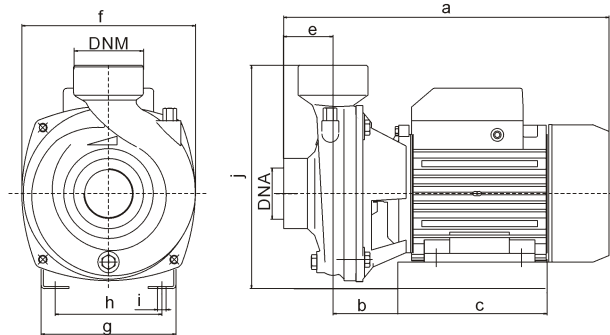
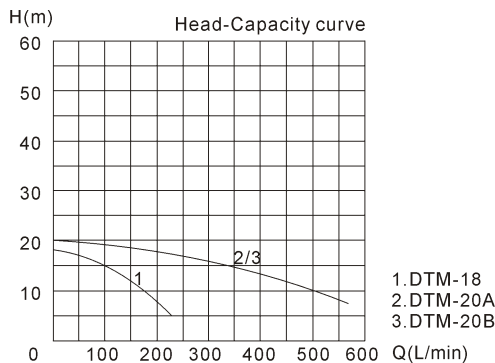

### OVERALL & INSTALLATION DIMENSIONS

Model	DIMENSIONS (mm)														
	DNA	DNM	a	b	c	d	e	f	g	h	i	j	k	l	m
DTM-18	1.5"	1.5"	320	133	145	100	54	190	131	100	8	244	--	--	--
DTM-20A	2"	2"	365	135	160	104	50	208	160	130	10	248	--	--	--

### PERFORMANCE SPECIFICATIONS

Model	Power		Q.max. L/min	H.max. m	Suct.max. m	Speed r.p.m	Inlet/Outlet mm	PACKAGE DIMENSIONS & G.W.				
	HP	kW						A	B	H	kg	
DTM-18	1	0.75	230	18			40x40	355	210	270	18.0	
DTM-20A	2	1.5	560	20	9	2850	50x50	390	220	270	22.0	

\* 110V, 110V/220V, 60Hz etc. models are available on request.