

## CPM Series CENTRIFUGAL PUMP

CPM series centrifugal pumps are single stage, high efficient electric pumps, consisted of a miniature motor and a single impeller centrifugal pump. They have a good performance in Big Capacity and High Head.

They are widely used in well-pumping, water supplying, decanting, mixing and irrigating for civil, industry and agriculture, etc.



CPM-158

### CONSTRUCTION:

#### PUMP Peripheral

Pump Body: Cast Iron  
Impeller: Brass / Aluminium/ P.P.O. Plastic  
Mechanical Seal: Carbon / Ceramic / Stainless steel

#### MOTOR Single Phase Heavy Duty Continuous Work

Motor Housing: Aluminium  
Shaft: Carbon Steel / Stainless Steel  
Insulation: Class B / Class F  
Protection: IP44 / IP54  
Cooling: External ventilation

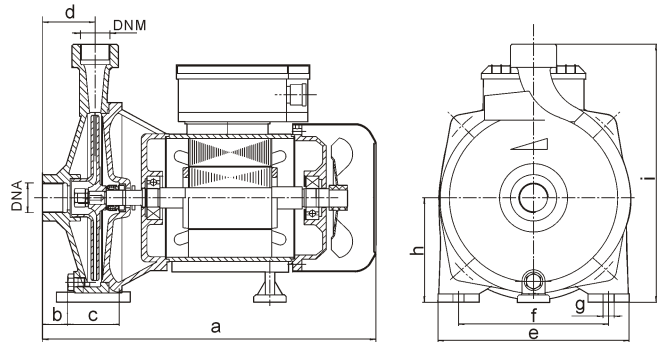
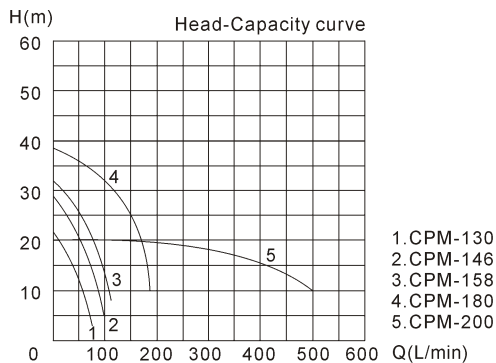

### OVERALL & INSTALLATION DIMENSIONS

Model	DIMENSIONS (mm)														
	DNA	DNM	a	b	c	d	e	f	g	h	l	j	k	l	m
CPM-130	1"	1"	295	--	--	42	170	135	10	82	211	--	--	--	--
CPM-146	1"	1"	305	--	--	44	190	160	10	100	242	--	--	--	--
CPM-158	1"	1"	305	--	--	44	190	160	10	100	242	--	--	--	--
CPM-180	1.5"	1.5"	360	--	--	53	207	160	10	112	262	--	--	--	--
CPM-200	2"	2"	388	32	--	60	207	160	10	112	259	--	--	--	--

### PERFORMANCE SPECIFICATIONS

Model	Power		Q.max. L/min	H.max. m	Suct.max. m	Speed r.p.m	Size mm	PACKAGE DIMENSIONS & G.W.			
	HP	KW						A	B	H	Kg
CPM-130	0.56	0.40	90	22	9	2850	25x25	310	170	230	8.9
CPM-146	0.75	0.55	100	28			25x25	340	210	260	12.2
CPM-158	1	0.75	110	32			25x25	340	210	260	13.8
CPM-180	1.5	1.10	180	38			40x40	400	220	280	21
CPM-200	2	1.50	500	20			50x50	420	220	270	23

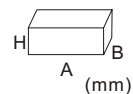

\* 110V, 110V/220V, 60Hz etc. models are available on request.